

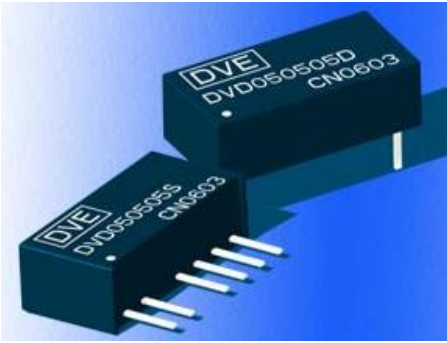

DVD Series
Isolated 1W Twin Output DC-DC Converters



FEATURES

- Efficiency up to 78%
- Optimized Volume
- Miniature SIP/DIP Package
- Twin Output Voltage
- 1kVDC Isolation
- Temperature Range -40°C to 85°C
- Industry Standard Pinout
- UL 94V-0 Package Material
- No Heatsink required
- No External Component Required
- PCB Mounting
- MTTF>3,500,000 hours

APPLICATIONS

The DVD Series are specially designed for applications where a group of polar power supplies are isolated from the input power supply in a distributed power supply system on a circuit board.

These products apply to:

- 1) Where the voltage of the input power supply is fixed (voltage variation $\leq \pm 10\%$);
- 2) Where isolation is necessary between input and output (isolation voltage =1000VDC);
- 3) Where the regulation of the output voltage and the output ripple and noise are not demanding.

Such as: purely digital circuits, ordinary low frequency analog circuits and IGBT power device driven circuits, etc.

SELECTION GUIDE

Order Code	Nominal Input Voltage (V)	Rated Output		Output Current		Efficiency (% Typ)	Package Style
		Voltage1 (V)	Voltage2 (V)	1Max (mA)	2Max (mA)		
DVD050505D	5	5	5	100	100	72	DIP
DVD050505S	5	5	5	100	100	72	SIP
DVD050509D	5	5	9	100	56	78	DIP
DVD050509S	5	5	9	100	56	78	SIP
DVD050512D	5	5	12	100	42	78	DIP
DVD050512S	5	5	12	100	42	78	SIP
DVD050515D	5	5	15	100	34	78	DIP
DVD050515S	5	5	15	100	34	78	SIP
DVD120505D	12	5	5	100	100	74	DIP
DVD120505S	12	5	5	100	100	74	SIP
DVD120509D	12	5	9	100	56	78	DIP
DVD120509S	12	5	9	100	56	78	SIP
DVD120512D	12	5	12	100	42	78	DIP
DVD120512S	12	5	12	100	42	78	SIP
DVD120515D	12	5	15	100	34	78	DIP
DVD120515S	12	5	15	100	34	78	SIP

INPUT CHARACTERISTICS

Parameter	Conditions	MIN	TYP	MAX	Units
Voltage Range	All DVD05 Types	4.5	5	5.5	VDC
	All DVD12 Types	10.8	12	13.2	

OUTPUT CHARACTERISTICS

Parameter	Conditions	MIN	TYP	MAX	Units
Output Power		0.1		1	W
Output Voltage Accuracy	See tolerance envelope graph				
Line Regulation	For V_{IN} change of 1%			1.2	%
Load Regulation	10% to 100% full Load			15	%
Temperature Drift	100% full load			0.03	%/°C
Temperature Rise	Full load		15	25	°C
Ripple	B/W=DC to 20MHz		50	75	mV p-p

ABSOLUTE MAXIMUM RATINGS

Short-circuit protection	1 second
Internal power dissipation	10% nominal power(typical)
Lead temperature 1.5mm from case for 10 seconds	300°C

- 1 All specifications measured at $T_A=25^\circ\text{C}$, humidity<75%, nominal input voltage and rated output load unless otherwise specified.
- 2 See below recommended circuits for more details.



DVD Series Isolated 1W Twin Output DC-DC Converters



ISOLATION CHARACTERISTICS					
Parameter	Conditions	MIN	TYP	MAX	Units
Isolation Test Voltage	Flash Test for 1 minute	1000			VDC
Resistance (V_{IN}/V_{OUT})	Viso=500VDC	1			GΩ
Resistance (V_{O1}/V_{O2})	Viso=500VDC	1			

GENERAL CHARACTERISTICS					
Parameter	Conditions	MIN	TYP	MAX	Units
Switching Frequency	Full load, nominal input voltage		100		kHz

ENVIRONMENTAL					
Parameter	Conditions	MIN	TYP	MAX	Units
Operation		-40		85	°C
Storage temperature		-55		125	°C
Storage humidity				95	%
Cooling	Free air convection				

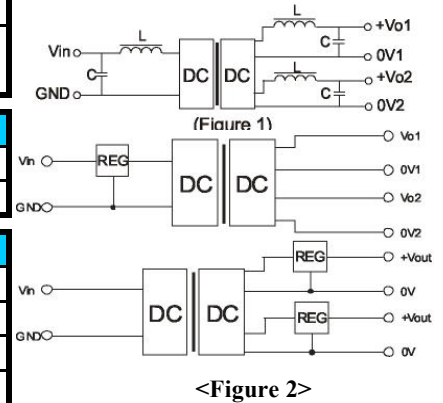

TYPICAL CHARACTERISTICS

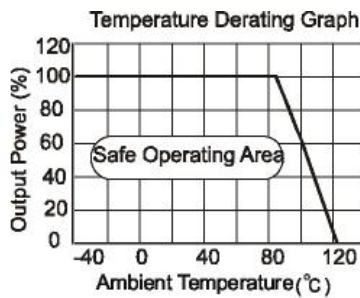
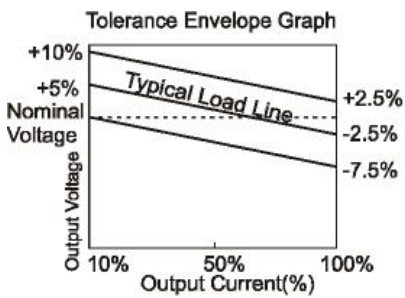

Overload Protection

Under normal operating conditions, the output circuit of these products has no protection against over-current and short-circuits. The simplest method is to connect a self-recovery fuse in series at the input end or add a circuit breaker to the circuit.

Output Voltage Regulation and Over-voltage Protection Circuit

The simplest device for output voltage regulation, over-voltage and over-current protection is a linear voltage regulator with overheat protection that is connected to the input or output end in series (see Figure 2).

OUTLINE DIMENSIONS & RECOMMENDED FOOTPRINT

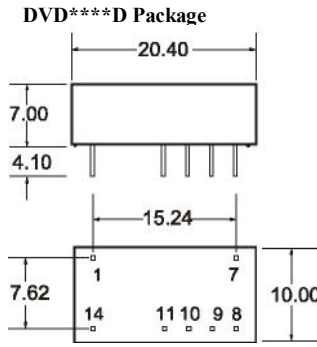
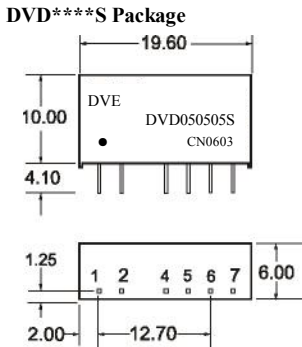

External Capacitor Table

V_{IN}	External capacitor	V_{OUT}	External capacitor
5VDC	4.7μF	5VDC	4.7μF
12VDC	2.2μF	9VDC	2.2μF
		12VDC	1μF
		15VDC	0.47μF

FOOTPRINT DETAILS

DVD***S Series		DVD***D Series	
PIN		PIN	
1	V_{IN}	1	GND
2	GND	7	NC
4	0V1	8	+Vo2
5	+Vo1	9	0V2
6	0V2	10	+Vo1
7	+Vo2	11	0V1
		14	V_{IN}

Note: All Pins on a 2.54mm pitch; All Pin diameters are 0.50 mm; all dimensions in mm.

APPLICATION NOTE

Filtering

In some circuits which are sensitive to noise and ripple, a filtering capacitor may be added to the DC/DC output end and input end to reduce the noise and ripple. However, the capacitance of the output filter capacitor must be proper. If the capacitance is too big, a startup problem might arise. For every channel of output, provided the safe and reliable operation is ensured, the greatest capacitance of its filter capacitor sees the external capacitor table. To get an extremely low ripple, an "LC" filtering network may be connected to the input and output ends of the DC/DC converter, which may produce a more significant filtering effect. It should also be noted that the inductance and the frequency of the "LC" filtering network should be staggered with the DC/DC frequency to avoid mutual interference (see figure 1).

Requirement On Output Load

To ensure this module can operate efficiently and reliably, a minimum load is specified for this kind of DC/DC converter in addition to a maximum load (namely full load). During operation, make sure the specified range of input voltage is not exceeded, the minimum output load is **not less than 10%** of the full load, and that this product should never be operated under no load! If the actual output power is very small, please connect a resistor with proper resistance at the output end in parallel to increase the load, or use products with a lower rated output power.